

TAPPA 14

ATTENZIONE

Nel caso in cui il riempimento non viene effettuato immediatamente : **zavorrare il serbatoio** con un minimo di 5 cm di liquido

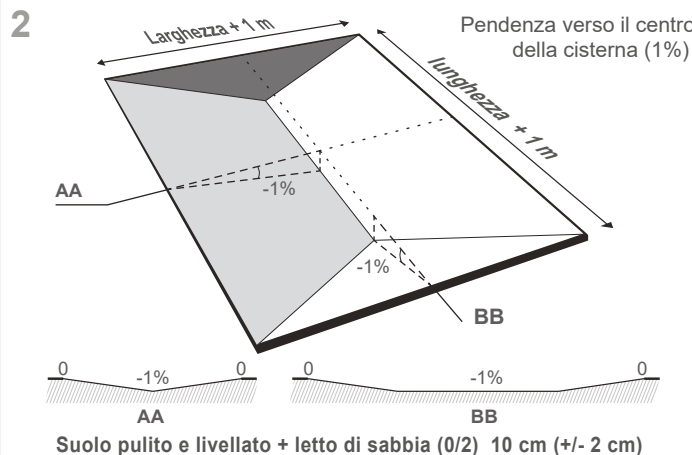

3 **IMPORTANTE**
Installazione del serbatoio in base al suo volume

V. (mc)	numero di persone
da 1 a 180	1 a 2
da 180 a 480	3 a 4
da 480 a 700	4 a 6

È formalmente vietato manipolare il prodotto con qualsiasi macchine per evitare i rischi di un deterioramento

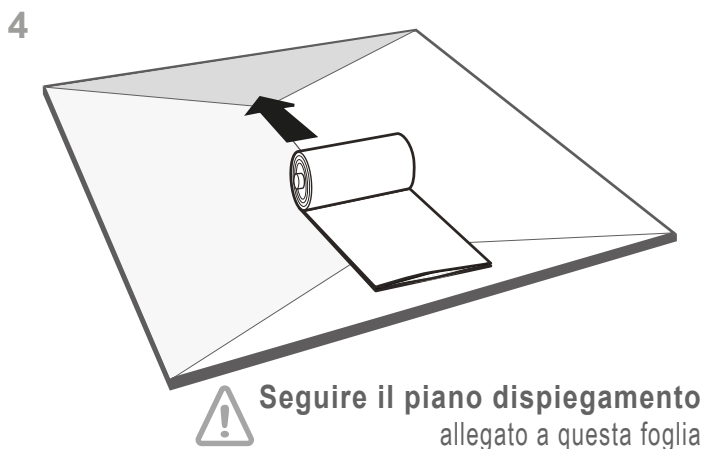

Seguire il piano dispiegamento allegato a questa foglia

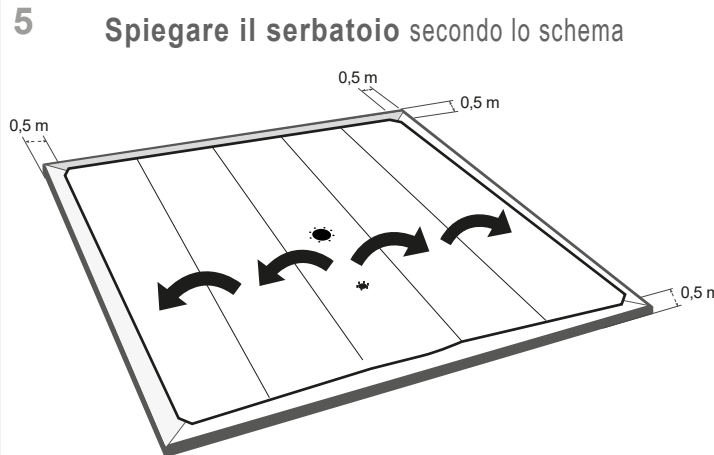

5 Spiegare il serbatoio secondo lo schema

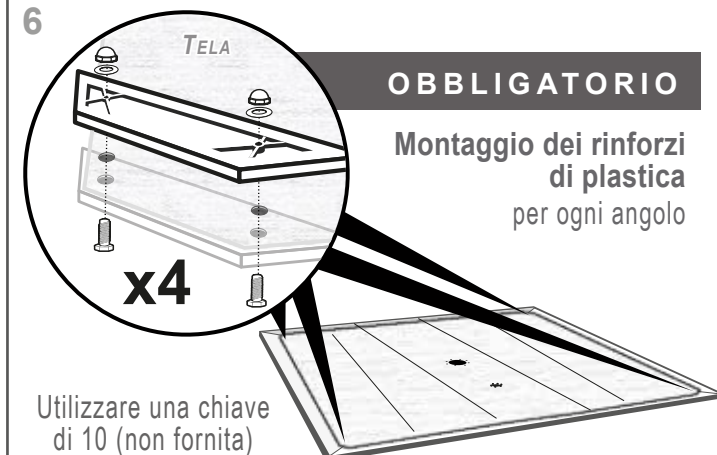

Questa tappa è necessaria per creare un tappeto d'aria sotto il serbatoio per facilitare il suo spostamento e il suo posizionamento



8 Scuotere e stendere bene il serbatoio per rimuovere tutte le pieghe

È ESSENZIALE posizionare bene il serbatoio prima del suo riempimento

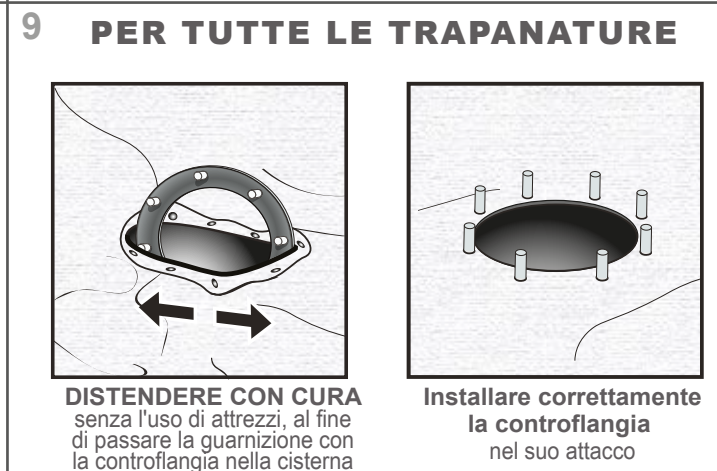



10 Utilizzare una chiave di 13 (non fornita)

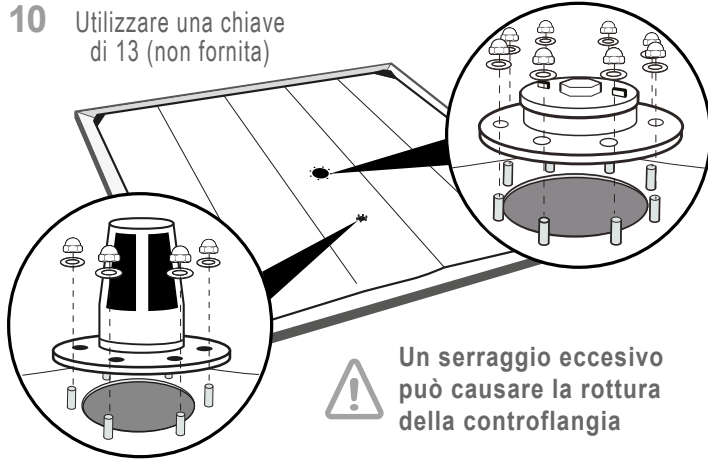

11 Utilizzare una chiave di 13 (non fornita)

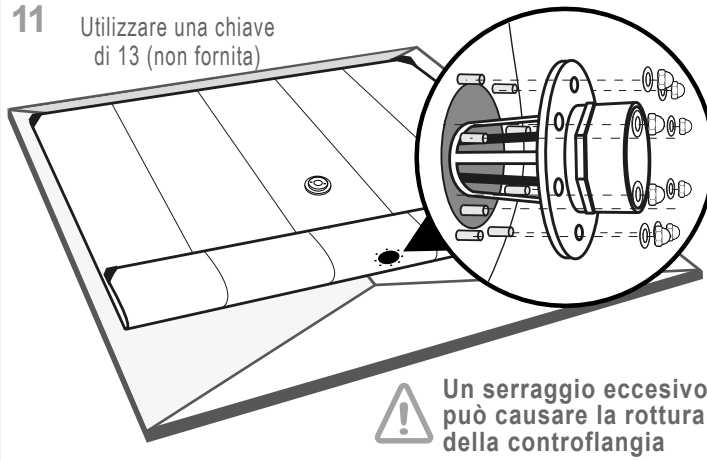

12 **TAPPE ESSENZIALI DA RINNOVARE**

